

FAG

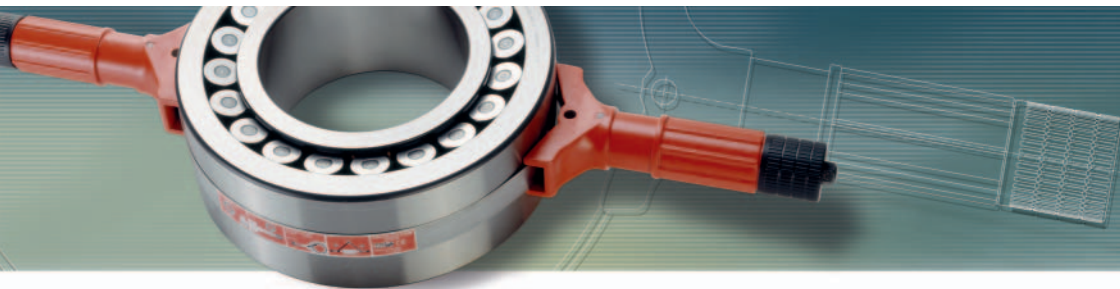

BEARING-MATE
Transport and Mounting Tool
User manual

SCHAEFFLER

Contents	Page
About the user manual.....	3
General safety regulations	5
Scope of delivery	9
Application	12
Inspection and maintenance	21
Appendix.....	23

About the user manual

The purpose of this user manual is to assist the user to become acquainted with the transport and mounting tool BEARING-MATE and use it for the intended purpose.

This user manual describes the construction and use of the transport and mounting tool BEARING-MATE and helps in avoiding hazards and extending the life of the device.

This user manual is part of the device and contains important information. It applies exclusively to the transport and mounting tool BEARING-MATE.

Warning and hazard symbols

The warning and hazard symbols are defined along the lines of ANSI Z535.6-2006.

The meaning of the guidelines and symbols is as follows:

Warning

In case of non-compliance, death or serious injury may occur.

Caution

In case of non-compliance, damage or malfunctions in the product or the adjacent construction will occur.

Availability

This user manual is supplied with each device and can also be ordered retrospectively.

If the user manual is absent, incomplete or illegible, the user may lack important information relating to safe use of the device and this may lead to incorrect usage. It must be ensured that this user manual is always complete and legible and that any persons using the device have the user manual available.

Legal guidelines

The information in this manual corresponded to the most recent status at the close of editing. The illustrations and descriptions cannot be used as grounds for any claims relating to devices that have already been delivered. Schaeffler Technologies AG & Co. KG accepts no liability for any damage or malfunctions if the device or accessories have been modified or used in an inappropriate manner.

Original user manual

This user manual is the original user manual in accordance with the Machinery Directive 2006/42/EC.

General safety regulations

This chapter brings together all the important safety regulations. Any person working with the transport and mounting tool BEARING-MATE must read this chapter and observe the guidelines.

Principles

The transport and mounting tool BEARING-MATE corresponds to the current level of technology and the recognised rules of safety practice.

If the safety guidelines are not observed, risks to life and limb for the user or third parties and extensive damage to other material assets may nevertheless arise during use.

Marking

The transport and mounting tool BEARING-MATE is marked by means of a nameplate with a unique serial number.

Usage for the intended purpose

The transport and mounting tool BEARING-MATE may only be used for the transport and mounting of heavy, rotationally symmetrical (round) parts such as rolling bearings.

The transport and mounting tool BEARING-MATE may only be used in accordance with the technical data, see Technical data.

Weights of more than 25 kg may only be lifted by 2 persons or by means of a lifting aid (crane).

The maximum lifting weight is 500 kg.

Further specifications:

- cylindrical outside surface
- non-separable bearing
- width of outer ring at least 60 mm
- width of outer ring no more than 270 mm.
In the case of spherical roller bearings and self-aligning ball bearings, use long retaining brackets.

Usage for the intended purpose also includes the following:

- All safety guidelines in the user manual must be observed
- All maintenance work must be implemented
- All relevant specifications on occupational safety and accident prevention must be observed.

Usage not for the intended purpose

The transport and mounting tool BEARING-MATE must not be used for the transport and mounting of separable bearings. It must not be used for the handling of other workpieces.

The steel strips must not be replaced by shorter or longer strips for use with bearings of a different diameter range.

The transport and mounting tool BEARING-MATE must not be used for the handling of bearings with an oily outer ring. Bearings with an oily outer ring may slip out of the tool when lifted.

Warranty

The manufacturer shall assume liability for warranties in relation to operational security, reliability and performance only under the following conditions:

- Mounting, connection, maintenance and repairs must be carried out by authorised and skilled personnel.
- The transport and mounting tool BEARING-MATE is used in accordance with the explanations in the technical datasheets.
- The limit values indicated in the technical data may not be exceeded under any circumstances.
- Conversion and repair work on the transport and mounting tool BEARING-MATE may only be carried out by the manufacturer.

Safety guidelines

Incorrect use of the transport and mounting tool BEARING-MATE represents a potential risk.

The following points must therefore be observed:

- Only authorised personnel should use the BEARING-MATE. Before use, this manual should be read.
- This user manual must always be followed precisely.
- The transport and mounting tool BEARING-MATE may only be used for non-separable rolling bearings. It must not be used for the handling of other workpieces.
- Before any use, the transport and mounting tool BEARING-MATE must be checked for damage. If damaged, it must no longer be used.
- The transport and mounting tool must not be used for the lifting or handling of bearings with a weight of more than 500 kg.

- When using the transport and mounting tool, suitable protective or safety equipment must be worn (safety boots, gloves and helmet).
- The bearing may only be lifted as high as is required by the application. If the bearing must be rotated from the horizontal to the vertical or vice versa, this must always be carried out at the smallest possible distance above the floor.
- Never stand under the bearing or place feet under it. Avoid all similar hazardous situations.
- The transport and mounting tool must not be used with accessories, such as a carrying sling, that are designed for a weight of less than 500 kg.
- If the transport and mounting tool is lifted by hand, this must always be carried out by two persons. In this case, the maximum weight must not be more than 50 kg.
- Lifting with the transport and mounting tool must not be carried out using chains.
- No modifications may be made to the transport and mounting tool.
- The transport and mounting tool must be checked in accordance with the local regulations at regular intervals. If you have any questions about the use of the transport and mounting tool, or if any uncertainties arise, please contact Schaeffler Customer Services.
- The transport and mounting tool must not under any circumstances be used for the handling of bearings with an oily outer ring. Bearings with an oily outer ring may slip out of the tool when lifted. The outer ring must be thoroughly cleaned using a solvent or cleaning agent.
- For transport with the aid of a crane and using carrying slings, additional means of support (securing belt) must be used.

Scope of delivery

The scope of delivery comprises:

- transport and mounting tool BEARING-MATE
- two short inner ring holders ③
- one tube of grease ④
- user manual.

The transport and mounting tool BEARING-MATE comprises:

- two retaining grips with rotating handles ①
- two clamping strips (steel strips) ②
- two inner ring holders ③
- pictogram label.

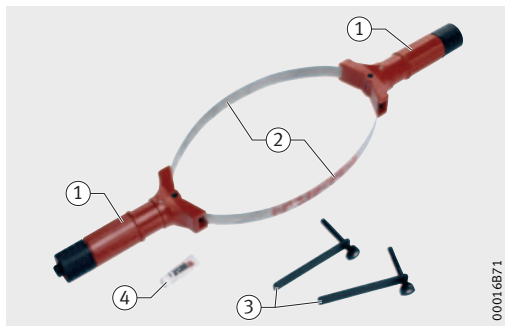

Basic operation

The transport and mounting tool BEARING-MATE was developed in order to allow easier transport and mounting of heavy, rotationally symmetrical parts such as rolling bearings. The transport and mounting tool BEARING-MATE is wrapped around the outer ring, with the two handles facing each other.

Within the specified diameter ranges, the transport and mounting tool can be adjusted to the various bearing diameters.

After mounting, the bearing and BEARING-MATE form a unit ⑤. The two opposing handles allow secure lifting and transport of the bearing.

In order to transport the unit comprising the bearing and BEARING-MATE by means of a crane, two suitable carrying slings of equal length must be used.

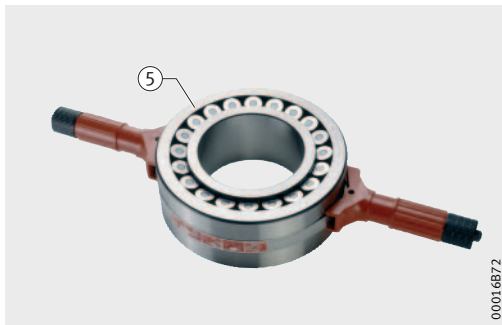

The carrying sling length (L) must correspond to at least 1,5 times the bearing diameter (D).

Before mounting, the unit can be rotated while it is suspended in the carrying slings. In this case, the handles form the axis of rotation. The BEARING-MATE can thus be used for the whole handling procedure, from transport through to mounting.

If the bearing is to be heated using an induction heating device, it is not necessary to remove the BEARING-MATE.

If heating is to be carried out using a flexible inductor and a medium frequency generator, the BEARING-MATE must be removed.

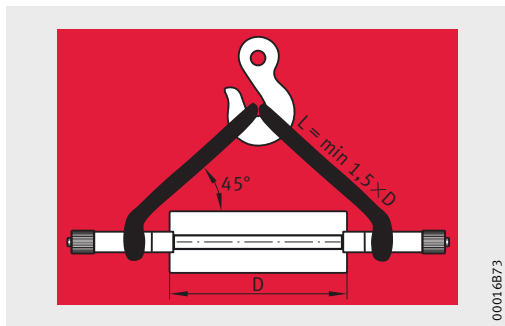

Application

Suitable bearings

Warning

Observe the maximum mass (m) and the permissible outside diameter of the rolling bearing (D), see label. Ensure that the outer ring is clean and free from grease and oil.

Further specifications of bearings:

- cylindrical outside surface
 - non-separable bearing
 - width of outer ring at least 60 mm
 - width of outer ring no more than 270 mm.
- In the case of spherical roller bearings and self-aligning ball bearings, use long retaining brackets.

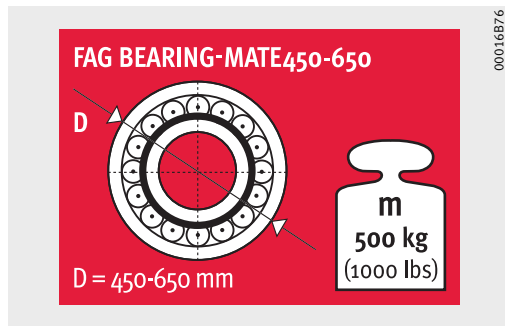

Checking and cleaning the transport and mounting tool

Warning

If the transport and mounting tool BEARING-MATE is damaged, it must not be used.

- Check whether all labels are present and easily legible, see page 24.
- Before each use, inspect the steel strips and handles for cracks, fractures, deformation, bends, notches, corrosion and wear.
- If the steel strips or handles are damaged, the complete tool must always be sent to Customer Services. E-mail, see page 25.
- Extend the steel strips to maximum length and clean them thoroughly.

Caution

The steel strips must be clean and free from grease and oil.



Cleaning of bearings

Before applying the steel strips, the bearing outer ring must always be cleaned.

Warning

A bearing with an oily outer ring may slip out of the transport and mounting tool BEARING-MATE. Ensure that the outer ring is dry.

Clean the bearing outer ring:

- Remove grease and oil as well as any foreign matter from the outer ring.
- Dry the outer ring.



00016BA5

Utilisation

After cleaning the BEARING-MATE and outer ring, use the BEARING-MATE as follows:

- Place the steel strips centrally on the outer ring, see label ①. The bearing can be lying horizontally or mounted vertically on a shaft.
- Rotate the ends of the handles uniformly in a clockwise direction by hand until the steel strips are firmly in contact with the bearing and are pulled in to the same extent. Observe the distances between the labels and the ends of the handles.
- Tighten the screw heads on the ends of the handles, observing the correct tightening torque, see label ②.
- Use a torque wrench to check whether the final tightening torque is between 14 Nm and 20 Nm.

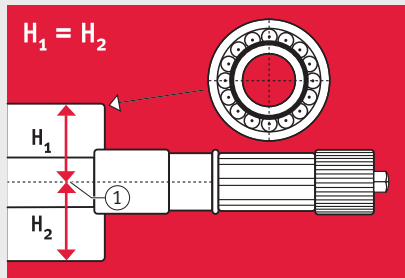

00016B78

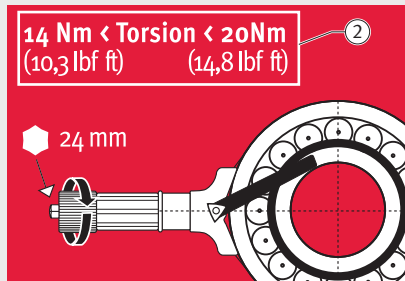

00016B79

Mounting the retaining brackets

In the case of spherical roller bearings and self-aligning ball bearings, the inner ring must be secured in place to prevent rotation.

! Caution

The retaining brackets must not extend beyond the inner ring and must both be fitted on the same side.

Secure the inner ring:

- The bearing outer ring is marked on one side. Insert both retaining brackets on this side.
- Align the retaining brackets parallel until they are in contact with the inner ring.
- Tighten the retaining brackets.



Fitting the carrying slings

Warning

For transport by means of a crane, use two carrying slings of equal length. Ensure that each carrying sling has a carrying force of at least 1000 kg. Chains must not be used, see label.

- Position the carrying slings between the contact face and the flange, ①. The carrying sling length (L) must correspond to at least 1,5 times the bearing diameter (D).
- Suspend the carrying slings on the crane hook.

Before mounting of the bearing, the unit can be rotated while it is suspended in the carrying slings.

In this case, the handles form the axis of rotation. The transport and mounting tool BEARING-MATE can thus be used for the whole handling procedure, from transport through to mounting.

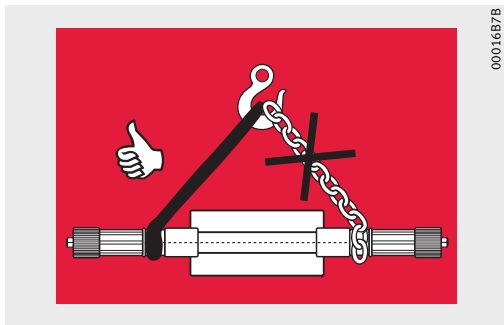

00016B7B

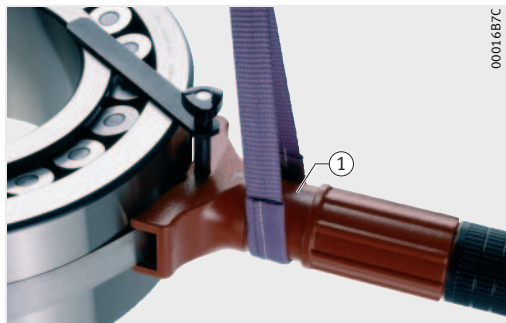

00016B7C

Transport

⚠ Warning

Apply additional means of support (securing belt, carrying force at least 1000 kg), ①.

Ensure that nobody is underneath the bearing at any time during transport.

Secure the hazard area.

Transport the bearing without shocks or vibration.

- Transport the bearing to the mounting location.

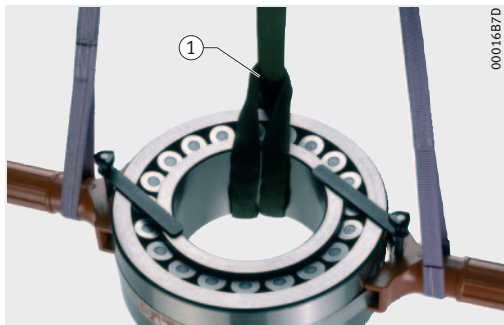

Mounting of bearings

- Rotate the bearing at the mounting location if necessary, ②. The handles serve as the axis when rotating the bearing.

! Caution

Ensure that the retaining brackets do not protrude beyond the inner ring.

- Mount the bearing.
- Remove the retaining brackets.
- Loosen the handles and remove the transport and mounting tool BEARING-MATE.

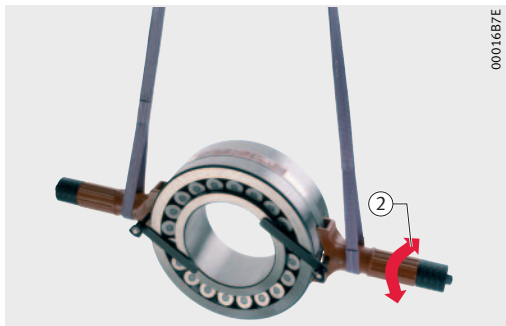

00016B7E

Heating of bearings

The transport and mounting tool BEARING-MATE can be safely heated by means of induction heating devices HEATER. The inner ring retainers must not be in contact with the inner ring of the bearing, since this allows heat to be conducted to the outer ring.

- Place the bearing, with the BEARING-MATE still mounted, on the induction heater.
- Heat the bearing inner ring to a maximum of +120 °C.
- Before lifting the bearing off the heating device, check the tightening torque using a torque wrench (14 Nm to 20 Nm).
- Move the inner ring retainers into the correct position.

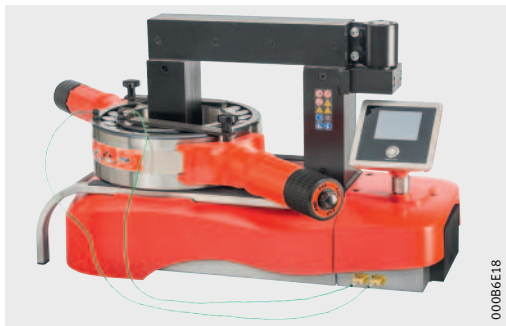

Inspection and maintenance

Inspection

The transport and mounting tool must be inspected at least once per year. The first inspection should be carried out one year after manufacture. If the relevant regulations require more frequent inspection, match the inspection period to the relevant regulations.

- Inspection must only be carried out by authorised personnel.
- Check the date of manufacture, ①.
13.06 indicates the year 2013, week 6.
- Before each use, inspect the tool for damage and in accordance with local regulations.
- Prepare and archive an inspection record: date of inspection, results (free from defects or description of any defects), name and position of the inspector.



Maintenance

Regular maintenance prevents excessive wear and increases the expected life.

- Every 6 months, lubricate the clamping strips at the 4 entry points using Arcanol MULTI2, ②.

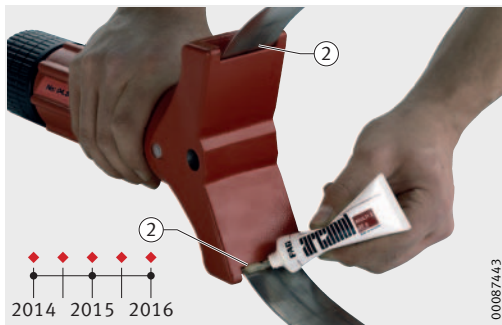

Appendix

Technical data

BEARING-MATE	
Load carrying capacity	500 kg
BEARING-MATE250-450	
Minimum diameter	250 mm
Maximum diameter	450 mm
Mass	6,3 kg
BEARING-MATE450-650	
Minimum diameter	450 mm
Maximum diameter	650 mm
Mass	6,5 kg
BEARING-MATE650-850	
Minimum diameter	650 mm
Maximum diameter	850 mm
Mass	6,7 kg
BEARING-MATE850-1050	
Minimum diameter	850 mm
Maximum diameter	1050 mm
Mass	6,9 kg

Inner ring retainer (length)	
Short	170 mm
Long	270 mm

Conversion, repair

Any modifications such as conversion or incorrect repair of the transport and mounting tool BEARING-MATE can lead to hazards for the user.

Warning

The transport and mounting tool BEARING-MATE must not be modified; conversion and repair are not permissible.

Repairs may only be carried out by Schaeffler Customer Services.

Certificates

The transport and mounting tool BEARING-MATE has been inspected by TÜV Product Service GmbH. A copy is available on request.

Accessories and spare parts

Schaeffler offers accessories and spare parts for the BEARING-MATE.

Accessories:

- Two long inner ring retainers, ①
Ordering number: BEARING-MATE.LOCKBAR270.

Spare parts:

- Two short inner ring retainers, ②
Ordering number: BEARING-MATE.LOCKBAR170.

■ Service kit:

Ordering number: BEARING-MATE.SERVICE-KIT

- One 20 g tube of Arcanol MULTI2, ③

(can also be ordered separately:
ARCANOL-MULTI2-20G)

- Two pictogram labels each for

BEARING.MATE250-450 = ④

BEARING.MATE450-650 = ⑤

BEARING.MATE650-850 = ⑥

BEARING.MATE850-1050 = ⑦

- Four labels ⑧ End of strip pull-in.

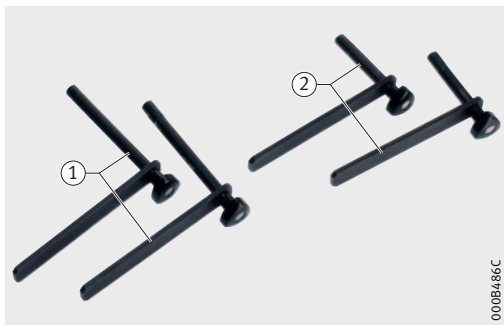

000B486C

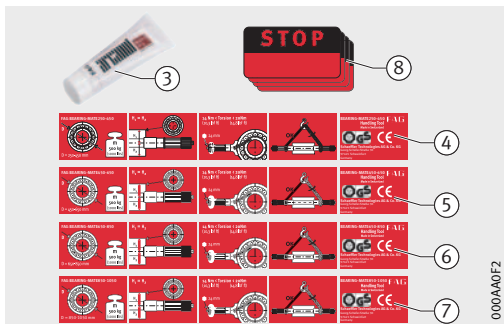

000A40FZ

Declaration of Conformity

A copy of the EU Declaration of Conformity in original size is available on request.

Contact

E-mail: industrial-services@schaeffler.com

SCHAEFFLER	
EN	
EC Declaration of Conformity	
in accordance with EC Machinery Directive 2006/42/EC	
We hereby declare that the product described below is in conformity with the applicable health and safety requirements of the EC Directive in terms of its design and type and in the execution we have brought into circulation. This declaration shall cease to be valid if any modification is made to the product without our agreement.	
Product description:	FAG Mounting and carrying tool
Product name:	BEARING-MATE
Type:	250-450; 450-650; 650-850; 850-1050
Voluntary review, applicable harmonized standards:	
EN 13155	Cranes, safety, non-fixed load lifting attachments.
Testing laboratory:	TÜV SÜD Product Service GmbH
Certificate no.:	Z1A 17 12 68163 005
Name and address of the authorized person for the technical documentation:	
	Schaeffler Technologies AG & Co. KG Georg-Schäfer-Straße 30 D-97421 Schweinfurt
	
Peter Schaefer Department Manager Mechatronics and Services	
Ort, Datum: Schweinfurt, 26.06.2018	
<small>Diese Erklärung beschränkt die Übereinstimmung mit den genannten Richtlinien, beinhaltet jedoch keine Zusage von Eigenschaften. Die Schweißverfahren der Betriebsanleitung sind zu beachten.</small>	
<small>Schaeffler Technologies AG & Co. KG • Georg-Schäfer-Straße 30 • D-97421 Schweinfurt • Tel.: +49 9721 91-0</small>	

000066E43

Schaeffler Technologies AG & Co. KG

Georg-Schäfer-Straße 30

97421 Schweinfurt

Germany

Internet www.schaeffler.com/services

E-mail industrial-services@schaeffler.com

In Germany:

Phone 0180 5003872

Fax 0180 5003873

From other countries:

Phone +49 9721 91-0

Fax +49 9721 91-3435

Every care has been taken to ensure the correctness of the information contained in this publication but no liability can be accepted for any errors or omissions. We reserve the right to make technical changes.

© Schaeffler Technologies AG & Co. KG

Issued: 2018, September

This publication or parts thereof may not be reproduced without our permission.

BA 01 GB-D